

Available online at www.synsint.com

Synthesis and Sintering

ISSN 2564-0186 (Print), ISSN 2564-0194 (Online)



Review article

Platinum-based electrochemical sensors for glucose detection: a mini-review

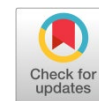

Milad Khanchoupan ^a, Alireza Pischevar ^a, Donya Souri ^b, Reza Yusofvand ^c, Zeynab Dabirifar ^{d,*}

^a Department of Chemical Engineering, Faculty of Engineering, Imam Hussein University, Tehran, Iran

^b Department of Chemistry, Payame Noor University, East Tehran Branch, Tehran, Iran

^c Department of Exceptional Talents, Faculty of Medicine Sciences, Lorestan University of Medical Sciences, Khorramabad, Iran

^d Department of Chemical Engineering, Faculty of Advanced Technologies, Quchan University of Technology, Quchan, Iran

ABSTRACT

This mini-review provides a comprehensive overview of platinum-based electrochemical sensors for glucose detection, focusing on recent advancements in material design, fabrication techniques, and the application of single-atom catalysts. Platinum's exceptional electrocatalytic properties and inherent stability have made it a cornerstone material for developing sensitive, selective, and stable glucose sensors. Performance evaluations from the literature reveal sensors with sensitivities exceeding $850 \mu\text{A}/\text{mM cm}^2$ and detection limits as low as $3.6 \mu\text{M}$. This review examines various approaches to enhancing sensor performance, including the use of different platinum nanostructures (e.g., nanoparticles, nanowires), the incorporation of conductive polymers or metal oxides, and the application of various electrochemical techniques (e.g., amperometry, cyclic voltammetry). Despite these advancements, challenges remain in achieving improved selectivity, stability, and cost-effectiveness. Future research directions include exploring novel platinum-based materials, developing advanced fabrication techniques such as 3D printing, integrating microfluidic platforms, and leveraging single-atom catalysis to enhance sensor performance further. Developing reliable and efficient platinum-based electrochemical glucose sensors is crucial for advancing diabetes management, biomedical research, and point-of-care diagnostics. This review aims to inspire continued research and innovation in this promising field.

© 2024 The Authors. Published by Synsint Research Group.

KEYWORDS

Platinum-based sensors
Electrochemical detection
Glucose sensors
Biosensor
Single-atom catalysts



1. Introduction

Typically, a sensor functions as an instrument that detects alterations in chemical, physical, or biological properties of materials and converts these changes into measurable signals, allowing for the designation of specific molecules in the complex environment. The primary elements of a sensor include the transducer, signal processor, and sensitive detector; the device produces the necessary signal, the signal processor

gathers, enhances, and displays this signal, while the sensitive detector selectively reacts to the substance being examined. An electrochemical sensor produces an electrical output when variations occur due to the target species. This type of analysis is extensively applied in environmental monitoring, biomedical fields, and food production due to its benefits. Electrochemical analysis stands out from other detection techniques as it does not necessitate large equipment, offers quick responses, and boasts high sensitivity and specificity. These sensors are

* Corresponding author. E-mail address: z.dabirifar@stumail.qiet.ac.ir (Z. Dabirifar)

Received 15 October 2024; Received in revised form 22 December 2024; Accepted 22 December 2024.

Peer review under responsibility of Synsint Research Group. This is an open access article under the CC BY license (<https://creativecommons.org/licenses/by/4.0/>).
<https://doi.org/10.53063/synsint.2024.44252>

predominantly employed for real-time monitoring of target analytes. A traditional three-electrode configuration is often utilized for precise electrical measurement and detection [1–7].

Creating working electrodes requires materials like carbon, various metals, and metal oxides. The use of bare electrodes in electrochemical experiments restricts the variety of electrodes available since the reactant molecules are near the electrode surface. Functional nanomaterials significantly improve the selectivity of electrodes for specific analytes, enabling customized adjustments to meet particular analytical needs. Once the target molecules are recognized on the electrode surface, data analysis, like concentration, is performed using electrochemical measurement techniques. These include differential pulse voltammetry (DPV), Linear sweep voltammetry (LSV), cyclic voltammetry (CV), square wave voltammetry (SWV), amperometry methods (*i-t* curve), and electrochemical impedance spectroscopy (EIS) [8, 9].

The measurement of blood glucose levels plays a vital role in recognizing diabetes. Enzyme-based sensors demonstrate strong specificity and sensitivity for glucose detection. Nonetheless, utilizing native enzymes comes with drawbacks such as high expenses, limited stability over time, and the need for complex immobilization processes. Innovative methods for glucose detection are emerging, incorporating acoustic-wave sensors, light-wave, and electrochemical approaches. Of these methods, electrochemical glucose sensors are recognized for their user-friendliness, cost-effectiveness, high sensitivity, and rapid response times. Electrochemical non-enzymatic glucose measurements frequently utilize precious metals and their alloys because of their enhanced responsiveness and favorable selectivity. However, the high cost of these materials has restricted their widespread application. Consequently, there is a need for non-enzymatic glucose measurement catalysts that offer outstanding efficiency at a lower cost. Substantial advancements have been achieved in the development of non-enzymatic glucose sensors over the last ten years [10, 11].

Developing various nanomaterials has led to the creation of numerous selective and sensitive glucose sensors. Glucose is among the most abundant monosaccharides found in nature. It is the primary energy source for all organisms and has a crucial function in biological processes. Normal fasting blood glucose levels typically range from 3.9 to 6.1 mmol/l. Both hypoglycemia and hyperglycemia can adversely affect an individual's health. Those suffering from hypoglycemia may feel hungry, experience heart palpitations, or even lose consciousness, whereas individuals with hyperglycemia face an increased risk of developing diabetes. Furthermore, assessing glucose content is an essential indicator of the quality of fruits and vegetables, serving as a guide in agriculture. From the discussion above, it is evident that precise, straightforward, rapid, and real-time glucose detection is vital for medical diagnostics, the food industry, and various other sectors, underscoring the significance and impact of the audience's work in these fields [12–15].

Recent advancements in electrochemical methods for glucose measurement have paved the way for new approaches to assessing glucose levels. Sensors that utilize glucose are extensively researched, with a growing emphasis on transitioning from invasive methods to wearable technology. The detection of advanced third-generation glucose enzyme sensors primarily relies on glucose oxidoreductase. Oxidoreductases, which play a key role as the biological agents in glucose enzymatic sensors, are mainly categorized into two types: glucose dehydrogenases (GDHs) and glucose oxidases (GO_x).

Furthermore, the redox cofactors associated with GDHs provide additional classification criteria [16–18].

Enzyme-based sensors utilizing GDHs and GO_x offer high specificity but are often hindered by high costs, limited stability, and complex immobilization processes. Therefore, non-enzymatic electrochemical approaches using novel materials are being actively investigated. This review focuses on platinum-based electrochemical sensors because of their superior performance characteristics compared to other non-enzymatic alternatives. Platinum exhibits exceptional electrochemical properties—high catalytic activity and excellent electron transfer capabilities—leading to enhanced sensitivity and selectivity in glucose detection [19–21]. Nanostructured platinum (nanoparticles, thin films) further improves performance by increasing the active surface area and facilitating more efficient interactions with glucose molecules [22, 23]. Recently, interest has been in developing susceptible and selective electrochemical glucose sensors to rapidly and accurately detect glucose levels. Among the various materials studied for glucose sensing applications, platinum-based electrodes have become potential candidates owing to their excellent biocompatibility and catalytic properties. This mini-review focuses on platinum-based electrochemical sensors for glucose detection. It highlights their design principles, fabrication techniques, and performance evaluation metrics to provide insights into their potential for practical healthcare and biomedical research applications.

2. Electrochemical glucose sensors

2.1. Mechanisms of glucose detection

Electrochemical biosensors are widely utilized today because of their enhanced repeatability, sensitivity, low cost, and ease of maintenance. Glucose sensors that utilize electrochemical methods can be categorized into those based on enzymes and those that do not. The distinction between enzymatic and non-enzymatic methods lies in whether they use direct or indirect electrooxidation reactions of glucose in absolute blood [24].

Measurements of glucose often rely on the engagement of one of three critical enzymes: GO_x, hexokinase, or GDH, where the interactions of GDH and GO_x play a crucial role in facilitating self-monitoring of glucose levels.

Three primary methods for electrochemically detecting glucose are measuring the oxygen consumed, assessing the hydrogen peroxide (H₂O₂) generated through enzymatic reactions, or utilizing an immobilized or diffusible mediator that facilitates the transfer of electrons GO_x to the electrode (Fig. 1). Two commonly used families of GDH-based amperometric biosensors include GDH-nicotinamide-adenine dinucleotide (NAD) and GDH-pyrroloquinolinequinone (PQQ). The upcoming sections will explore the mechanisms associated with enzymatic and non-enzymatic glucose sensing methods.

2.1.1. Mechanism of enzymatic glucose sensors

In 1962, Clark and Lyons [1] established the groundwork for contemporary glucose-sensing technology through innovative research on the initial enzyme-based electrode. This electrode incorporated GO_x immobilized in a semipermeable membrane, facilitating the transformation of glucose into H₂O₂ and gluconic acid. The redox cofactor flavin adenine dinucleotide (FAD) has a critical task in the catalytic performance of GO_x by accepting electrons and being reduced

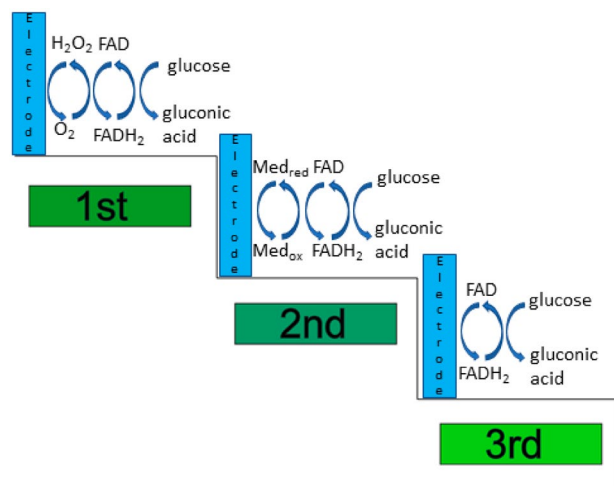

Fig. 1. Diagram illustrating the mechanisms of enzymatic glucose oxidation across the production of three biosensors [24].

to FADH₂, leading to the generation of H₂O₂ during the cofactor's regeneration. Subsequently, H₂O₂ undergoes oxidation at a Pt anode, allowing for the detection of electron transfer events that correlate directly with glucose levels.

In 1970, Clark [2] made further progress by developing a two-electrode setup for glucose detection, converting electro-inactive substances into electroactive ones through enzyme-driven reactions. The purpose of this system was to reduce interference from various other compounds found in the sample. Despite a notable advancement, the initial glucose sensors did not qualify as genuine biosensors. In 1975, the first commercially accessible glucose sensors were introduced, employing amperometric detection of H₂O₂ derived from human blood samples. The Yellow Springs Instrument Company (YSI) made a groundbreaking contribution to glucose monitoring technology by developing a new sensor [25, 26].

Recent developments in surface chemistry and the fabrication of devices have greatly enhanced the area of commercial electrochemical glucose sensors [27]. A range of inorganic redox mediators and couples—like methyl viologen, tetracyanoquinodimethane (TCNQ), quinones, tetrathiafulvalene (TTF), thionine, methylene blue, ferrocene, and ferricyanide—enables the transfer of electrons from the enzyme layer to working electrode surface [28]. Ferrocene is particularly popular because it reacts quickly with enzymes, works effectively over a broad pH spectrum, and exhibits reversible electron transfer kinetics. Since their launch in 1984, second-generation glucose sensors have surpassed the performance of the first-generation models. This advancement is primarily due to redox couples or mediators, which provide greater sensitivity to dissolved oxygen, even under challenging interference conditions and at lower potentials. Medisense Inc. introduced the ExacTech sensor as the first glucose monitoring device specifically developed for home use. It employed an innovative screen-printing technique enabling the creation of disposable, compact, wearable, and easy-to-use electrodes. Every test strip included working electrodes and miniaturized screen-printed reference, with the working electrode covered in essential sensing elements like stabilizers, linking agents, GO_x, and electron-shuttle redox mediator [29]. Although the importance of second-generation glucose detectors is still discussed, their emergence has notably sped up the advancement of finger-pricking glucose meters for home use.

The introduction of home glucose meters that use mediated systems has not significantly improved our comprehension of the biochemical makeup of GO_x, nor has it resolved concerns regarding the solubility of intermediates, toxicity, and the overall stability of these systems across different temperatures, pH levels, and humidity. Consequently, scientists globally are working to enhance sensor efficiency through diverse methods facilitating electron transfer from the center of GO_x redox to the electrode surface. Such methods involve chemically altering GO_x with electron-relay compounds, connecting GO_x with electron-conductive redox hydrogels, and using nanomaterials as electrical linkers. A different approach aims to facilitate direct electron exchange between the electrode and the enzyme, bypassing the requirement for intermediaries. This is achieved through needle-shaped implantable devices designed for continuous glucose monitoring. These devices operate at low potentials, close to the enzyme's redox potential, minimizing the need for additional components and simplifying the monitoring process. The lack of mediators in these biosensors facilitates more efficient detection of glucose molecules [28].

Although still in the initial phases of development, third-generation sensors exhibit potential, especially those constructed on nanomesoporous electrode surfaces. Nonetheless, they encounter considerable constraints since only a tiny subset of enzymes has proven capable of directly transferring electrons to the working electrode. The existing research concerning glucose detection does not provide adequate support for methods that do not utilize mediators. To achieve the best electron transfer, optimizing the interactions between the electrode and the enzyme is crucial. Carbon-based components, including nitrogen and phosphorus-doped multi-walled and single-walled carbon nanotubes, offer superior platforms to create high-efficiency biosensors for the detection of glucose. The characteristics and amounts of these phosphorus and nitrogen species can be precisely regulated on the surface of carbon materials, acting as attachment sites for the immobilization of PQQ-GDH [30–32].

2.1.2. Mechanism of non-enzymatic glucose sensors

Enzyme-based glucose sensors, while sensitive, face several drawbacks, including susceptibility to high cost, environmental changes, and stability issues. The constraints associated with traditional methods have spurred the creation of glucose sensors that do not rely

on enzymes, which provide benefits related to their sensitivity and are viewed as a promising next-generation technology [33–35]. Non-enzymatic glucose sensors find widespread applications in catalysis, environmental monitoring, and biomedical devices. Noble metals and their alloys have become the central focus of research in non-enzymatic glucose electrooxidation due to their strong catalytic properties [36].

Two main approaches are used to enhance the efficiency of enzyme-free glucose sensors. One method focuses on altering the material's structural arrangement, expanding the surface area, and increasing the active sites for electrochemical reactions. The other strategy involves creating hybrid components by integrating or doping the base material with different substances, leading to enhanced functionality. The construction of glucose sensors often involves using metal-organic frameworks (MOFs), metals and their compounds, inorganic carbon materials, conductive polymers, and other materials to construct the working electrode of the sensor. The integration of these materials leverages their respective strengths, leading to improved performance of non-enzyme sensors, including lower detection limits, higher sensitivity, and a broader linear range.

While platinum nanoparticles are broadly employed in non-enzymatic glucose sensors, they face challenges such as slow kinetics, poor selectivity, and limited sensitivity [35]. To address these limitations, researchers have explored alternative materials, including alloys with Fe, Ni, Au, and Co, and combinations with MWCNTs (multi-walled carbon nanotubes) and carbon to enhance surface catalytic activity, stability, and sensitivity. While noble metals are generally expensive, non-noble metals like Fe, Mn, Zn, Co, Cu, Ni, and metal sulfides and oxides have emerged as promising alternatives for non-enzymatic glucose electrooxidation.

Enhancing the accessible active surface area is a key approach to boosting the performance of non-enzymatic glucose sensors. Materials with good porosity, including macroporous, microporous, and mesoporous structures, are therefore being explored for sensor

fabrication. Nanomaterials combined with graphene and its derivatives as substrates have proven to be highly effective, thanks to their extensive surface area, superior conductivity, and enhanced electron transfer, which contribute to more efficient glucose electrooxidation and detection [36].

Because of their unique physicochemical properties, two-dimensional (2D) substances have emerged as a favorable class for sensing applications. Their high surface-area-to-volume ratio has made them particularly well-suited for sensing target glucose molecules, leading to high sensitivity (Fig. 2) [37]. Furthermore, their high mechanical strength, optical transparency, and flexibility enable the miniaturization of sensors based on 2D materials, paving the way for their integration into the Internet of Things (IoT) platform.

The interaction between target molecules or ions and 2D materials is controlled by two primary mechanisms: physisorption and chemisorption. Physisorption is characterized by non-covalent interactions at the 2D material surface, whereas chemisorption is defined by establishing covalent bonds. Typically, non-covalent interactions are preferred for quick responses. Due to its honeycomb lattice, graphene tends to create pi-bonds with molecules, while MoS₂ engages through van der Waals interactions, which is typical of transition metal dichalcogenides [38, 39].

The single-layer structure of graphene enhances carrier mobility, rendering it an outstanding 2D substance for detecting glucose. The absence of a band gap facilitates unimpeded charge transport [40]. Techniques such as surface decoration composite formation with other substances, functionalized reduced graphene oxide (rGO), or graphene oxide (GO) are commonly employed to improve graphene's sensitivity in glucose detection. For example, nitrogen plasma treatment can yield N-doped graphene, whereas Cu-doped graphene may be synthesized through electrodeposition. These approaches have resulted in highly stable, selective, and sensitive materials [41, 42].

In glucose sensing applications, GO_x is commonly used as a catalyst.

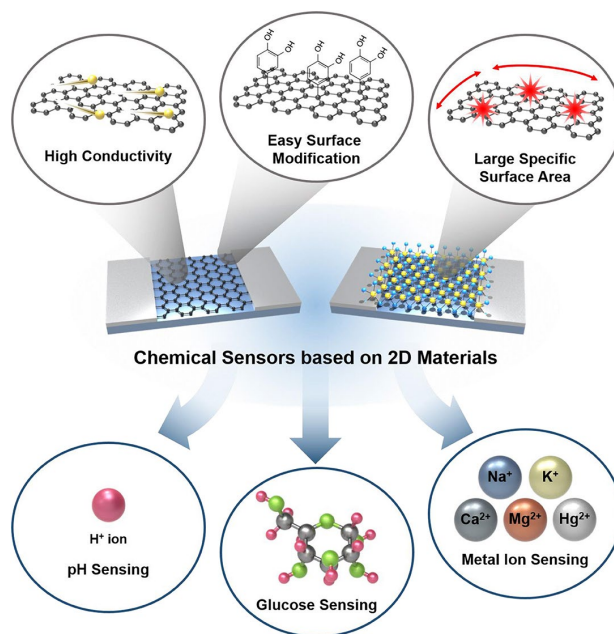

Fig. 2. A conceptual diagram illustrating chemical sensors that leverage 2D materials, highlighting the benefits of these materials and their use in detecting ions and molecules [37].

Nevertheless, GO does not work well with organic polymers. The chemical modification of GO using N-succinimidyl acrylate allows GO_x to be incorporated, demonstrating the performance of different graphene electrodes across various pH levels in a challenging environment [43].

Nanoparticle decoration on 2D materials can be performed via electrochemical etching, fabricating nano-band electrodes, and depositing metal nanoparticles. Parlak et al. [44] have clarified the sensing mechanism involved with Au-doped MoS_2 . Research indicates that Au nanoparticles enhance glucose sensitivity. Specifically, Parlak et al. utilized ultrasonication to disperse Au nanoparticles, whereas Su et al. [45] employed a hydrothermal approach to synthesize them directly on MoS_2 . MoS_2 nanosheets suspended in a phosphate buffer solution and exposed to ultrasonication exhibit a selective response to glucose molecules. Different metals like Ni, Ag, Au, Cu, and Pt have been integrated into MoS_2 substrates through methods including liquid exfoliation solution-based methods, electrodeposition, and hydrothermal processes [46–49]. Creating bimetallic nanoparticles continues to pose challenges and necessitates additional research.

SnS_2 is one of the n-type semiconductors with a bandgap ranging from 2.18 to 2.44 eV and can be utilized for detecting glucose and H_2O_2 . Its acid resistance and stability in air, along with photocatalytic properties, render it a desirable material. The stability and reproducibility of an MWCNT– SnS_2 sensor that responds amperometrically only to glucose without reacting to ascorbic or uric acid are demonstrated. This sensor was evaluated under a potential of 0.43 V in a solution of phosphate buffer at pH 6.0 [50].

3. Parameters controlling glucose biosensors

3.1. Enzymes

GO_x and GDH represent two enzyme categories commonly employed in glucose biosensors to facilitate the redox reaction involving glucose. The characteristics of these enzymes vary concerning their redox potential, selectivity, and cofactors for D-glucose. The GO_x enzyme is extensively studied because it is easily handled and exhibits high specificity for substrates in glucose-rich environments [51, 52]. GO_x is commonly produced using the fungus *Aspergillus niger*. The structure of the GO_x enzyme consists of a homodimer formed by two identical subunits, along with a non-covalently attached FAD coenzyme that is firmly integrated into the enzyme's active site. FAD resides within funnel-shaped active sites with an aperture of 100 Å [53]. As a redox cofactor, FAD serves as a coenzyme that utilizes oxygen as an external electron acceptor and functions and generates H_2O_2 as an electron transporter throughout the catalytic process. The GO_x enzyme provides benefits such as cost efficiency and significant stability in applications involving glucose biosensors. However, its performance relies on the oxygen levels in the electrolyte solution [54, 55].

Unlike traditional methods that use oxygen as an electron acceptor, GDH facilitates electron transfer to various organic and synthetic acceptors. The structure of GDH is that of a monomer composed of two distinct domains: a central binding domain for nucleotides and a catalytic domain on either side. GDH can be classified according to its cofactor, primarily falling into three categories: pyrroloquinoline quinone (PQQ), FAD, and NAD [56]. The effectiveness of the GDH enzyme is contingent upon the specific cofactor employed. FAD-GDH is typically expensive and demands considerable preparation, whereas

PQQ-GDH shows limited selectivity because of interactions with different saccharides. NAD-GDH demonstrates superior stability and selectivity but faces challenges in aligning with suitable mediator properties.

3.2. Electrode materials

The interaction between the working electrode and the electrolyte solution interface significantly influences the performance of electrochemical glucose biosensors. The variety of working electrodes and their surface configurations play a crucial role in determining the electrochemical efficiency of these biosensors. There is a constant demand for glucose biosensors that exhibit reliable reproducibility, high sensitivity, and cost-effective working electrodes. Prior studies have documented modifications to electrodes for glucose biosensors utilizing solid carbon electrodes, such as magnetic glass carbon and carbon paste electrodes [57, 58], as well as solid noble metal electrodes like Au and Pt [59, 60]. A significant drawback of solid bulk electrodes is the challenge of adapting their development process to disposable electrodes intended for home blood glucose monitoring. Disposable electrodes, however, benefit from rapid screening and on-site tracking due to their affordability, high sample throughput, and straightforward incorporation into mass production methods. These disposable working electrodes can be classified into carbon-based, flexible, or glass-based and are typically produced through screen printing, deposition, casting, and sputtering techniques.

Disposable electrodes are ideal for glucose biosensing because they are compact, portable, and cost-effective for at-home glucose monitoring. Disposable electrodes are frequently augmented with various nanomaterials to enhance their electrochemical performance in glucose measurement. Techniques for surface modification include drop casting, electrodeposition, direct growth, and dip coating methods. Among the various disposable electrodes, screen-printed carbon electrodes (SPCE) stand out for their simplicity, as they integrate reference, counter, and working electrodes into a single substrate. This is due to their capacity to bend and stretch, making them ideal for continuous and wearable glucose monitoring systems.

3.3. Electrolyte

The choice of electrolyte in enzymatic glucose biosensors is crucial, as it significantly influences the biosensor's performance. Phosphate buffered saline (PBS) is frequently used due to its ion concentration and osmolality, which resemble those of the human body. The pH level of PBS plays a vital role in regulating the electrochemical signals associated with the performance of glucose biosensors. Enzymes exhibit variations in their structure and conformation based on the electrolyte's pH. Alterations in the enzyme's structure influence its activity. The electrolyte's pH can modify the ionization state of enzyme amino groups, which is typically reversible [61].

The redox characteristics of the GO_x enzyme are affected by the concentrations of protons (H^+) and hydroxide ions (OH^-) in the electrolyte under acidic conditions ($pH < 4$); the activity of GO_x diminishes because of denaturation. In alkaline environments ($pH > 8$), the activity of GO_x is reduced due to a decreased concentration of protons. The optimal redox behavior of the GO_x enzyme occurs at neutral pH levels, specifically between 6.8 and 7.4. This emphasis on the importance of the redox behavior of the GO_x enzyme at neutral pH levels is crucial for the audience's understanding and appreciation of

glucose biosensors. In contrast, non-enzymatic glucose biosensors typically operate under alkaline conditions, with a pH range of 8 to 10. A NaOH solution, generally at a concentration between 0.1 and 0.5 M, is commonly used for glucose oxidation reactions. Alkaline conditions are crucial since the OH⁻ in the electrolyte facilitates the catalytic reaction involving β-D-glucose. Numerous studies have explored non-enzymatic glucose biosensors operating in neutral electrolyte conditions, specifically at pH levels between 7 and 7.4. The pH levels of human bodily fluids, such as serum, tears, and sweat, utilized as samples in glucose biosensors, are typically neutral. Consequently, a working electrode incorporating bimetallic compounds and porous nanomaterials was designed to boost the catalytic reaction and improve electron transfer during glucose detection [62].

4. Platinum-based electrochemical sensors for glucose detection

The development of glucose biosensors, a significant milestone in the field, has revolutionized the diagnosis and prediction of diabetes. Moreover, these biosensors play a critical role in the drink, food, and fermentation sectors, where the accurate measurement of glucose levels is crucial. The enzyme GO_x, a key player in this development, was first utilized in creating glucose biosensors [63, 64].

In 2004, a biosensor that operates on the principle of amperometry with H₂O₂ was developed, marking a significant advancement in the field. This device, manufactured through the use of oxidases and the enzymatic oxidation of the target substance, represents a continuous improvement in glucose biosensor technology. The incorporation of GO_x into a polypyrrole membrane on a platinum electrode effectively immobilizes the enzyme, enhancing the sensor's performance. The sensor exhibits a sensitivity of 103 μA/mM cm², a testament to the promising future of glucose biosensors [65].

Although the sensor is highly responsive, its reaction speed and the smallest amount of glucose it can detect are still significant factors to consider. To better understand how glucose sensors work, researchers led by Zhu et al. in 2006 utilized the unique properties of carbon nanotubes (CNTs) related to heat, electricity, and light [66]. They used CNTs to cover platinum particles (with a diameter between 2 and 3 nanometers), creating a structure of platinum nanoparticles encased in dendrimers (PtDENs). These structures were then combined with multi-walled carbon nanotubes (MWCNTs). The MWCNTs act as a solid surface where metal nanoparticles can attach and become more concentrated. They also play a role in facilitating the transfer of electrons between enzymes and other biological molecules, as described by researchers Guiseppi-Elie and colleagues in 2002 [67]. This electrode design promotes a high rate of oxidation and reduction reactions while limiting the impact of unwanted substances. The results demonstrated that this sensor can respond within 5 seconds and detect glucose concentrations as low as 2.5 millimolar. However, while creating this biosensor is straightforward and manageable, the minimum amount of glucose it can detect could be better.

A research team led by Wu et al. [68] developed a glucose sensor using MWCNTs, the enzyme GO_x, and gold nanoparticles. This sensor could detect glucose levels ranging from 0.1 to 10 mM, with a detection limit of 6.7 M and a sensitivity of 2.527 A/mM. Wen et al. [69] developed a straightforward method for creating a platinum-coated carbon nanotube (PtCNT) material. This involved heating glucose and a reducing agent on a film composed of anodic aluminum oxide and nanoparticles. This

process ensured that the GO_x enzyme retained its biological activity. This composite material contained many oxygen-containing groups, which enhanced its solubility in water, its compatibility with biological systems, and the activity of the GO_x enzyme [70]. By combining the composite material with the GO_x enzyme, researchers created a highly effective glucose biosensor that used the Pt-CNT material as its basis. This sensor could detect glucose levels within a detection limit of 0.055 mM, with a linear range of 0.16 to 11.5 mM, and exhibited good reliability and selectivity.

Feng et al. [71] employed a straightforward physical adsorption approach to create glucose sensors using TiO₂ nanotube arrays (TiO₂ NTAs) modified with graphene, immobilized GO_x, and platinum nanoparticles (Pt/GR/TiO₂ NTAs). The sensor's response rate displayed a linear correlation with glucose concentration ranging from 0.1 to 8 mM. The sensor's sensitivity achieved a value of 0.94 μA/mM cm². Akkaya et al. developed a novel electrochemical biosensor capable of switching, which was fabricated using a composite modification involving the deposition of Pt nanoparticles and the reduction of GO_x [72]. Tannic acid (TA) was utilized to simultaneously reduce graphene oxide (GO) and Pt⁴⁺, facilitating the immobilization of GO_x. The resulting surface exhibited switchable behavior, responding to oxygen levels, pH, and temperature variations. Furthermore, the biosensor incorporates polyisopropylacrylamide (PNIPAAm), which can form hydrogen bonds and create a zipper-like structure that enables switchable behavior. The biosensor displayed a decrease in the GO_x-FAD current as glucose concentration increased within the range of 2–10 mM. This reversible interaction demonstrated the biosensor's acceptable repeatability, a sensitivity of 27.51 μA/mM cm², and a detection limit of 1.21 μM.

Yang et al. [73] integrated nanocoated substances within a GO_x solution to improve sensitivity and reduce the detection threshold. They developed a range of one-dimensional mesoporous platinum nanotubes (MPtNTs), which acted as electrode modifiers for a biosensor enhanced by 1D mesoporous Pt nanotubes. The MPtNTs exhibited wall thicknesses ranging from 7.2 to 12.8 nm. Mesoporous nanoparticles are ideal for enzyme immobilization because they offer a large capacity and a high specific surface area that enhances enzyme activity [74, 75]. The biosensor increased response current to glucose as the concentration increased. The MPtNTs biosensor has a wall thickness of 7.2 nm, a linear range from 0.025 to 2.20 mM, and a detection limit of 0.2 μM (S/N = 3). The estimated Michaelis constant (K_m) was less than 3.4 mM, indicating good anti-interference selectivity and properties.

The field of biosensors has experienced significant advancements, driven by the optimization of various performance metrics such as response time, detection limit, and sensitivity. These developments have led to the creation of crystalline porous materials with a periodic network structure composed of organic linkers, metal-organic frameworks (MOFs), and metal ions [76]. These materials, with their adjustable pore sizes, large hydrophilic/hydrophobic groups, and ultra-high porosity, offer versatile properties for various applications [77–79]. Notably, the MOF-74 group is a relatively robust framework material, exhibiting water and commendable thermal stability [80].

In contrast, Uzak et al. [81] immobilized GO_x onto a hybrid nanomaterial composed of platinum Pt NP-modified reduced graphene oxide (rGO)/ZnMOF-74. This biosensor demonstrates rapid response, a high current density, and sensitivity to glucose facilitated by efficient electron transfer capacity. The data revealed that a consistent current signal can be acquired within 40 seconds. The biosensor exhibited good

selectivity, as evidenced by a low relative standard deviation (RSD) of 4.16% in the presence of various interfering reagents. This biosensor demonstrates a linear range of 0.006 mM with a sensitivity of 64.51 $\mu\text{A}/\text{mM cm}^2$ and a detection limit of 1.8 μM ($S/N = 3$).

While enzyme-based sensors offer sensitivity, they are often susceptible to operating conditions (pH, temperature, and humidity), are relatively expensive to produce, and exhibit limited stability [82]. These constraints have created glucose sensors that do not rely on enzymes, providing a more reliable option. To enhance the efficiency of glucose biosensors, Liu et al. [83] utilized platinum nanofibers and platinum nano corals, adjusting electrodes with gold particles to develop sensors that can directly identify glucose in alkaline and neutral solutions. The sensor demonstrated high sensitivity in alkaline solutions (24.6 $\mu\text{A}/\text{mM cm}^2$), a broad linear range of 7.2 mM, and a low detection limit of 3.2 μM . When tested in a neutral medium, the sensor exhibited an increased sensitivity (2.1 $\mu\text{A}/\text{mM cm}^2$), linear range, and detection limit, reaching 28 μM . Dhara and colleagues [3] (2014) successfully developed a serum

glucose sensor using rGO in conjunction with monoclinic crystal copper oxide nanomaterials and cubic crystal platinum nanomaterials, employing a single-step chemical approach. The resulting sensor exhibited a detection limit of 0.01 μM , a sensitivity of 3,577 $\mu\text{A}/\text{mM cm}^2$, and a linear response range of 12 μM .

Şavk et al. [82] created Pt–Ni nanocomposites that incorporated activated carbon, referred to as PtNi/AC. These PtNi/AC nanocomposites were applied to enhance the surface of a glassy carbon electrode (GCE), creating an electrochemical glucose biosensor that does not require enzymes. These PtNi/AC nanocomposites exhibited a remarkable ability to oxidize and catalyze glucose without needing enzymes. The addition of glucose resulted in a significant alteration of the current intensity. The present density advanced steadily, getting a stable current within 2 seconds. The biosensor demonstrated a sensitivity of 40.9 mA/mM cm^2 , a linear range from 0.025 to 12 mM, and a detection limit of 0.052 μM . This mini-review summarizes recent advances in platinum-based electrochemical sensors for glucose detection in Table 1.

Table 1. Recent advances in platinum-based electrochemical sensors for glucose detection (2019–2024).

Year	Modified electrode	Potential (V)	Sensitivity ($\mu\text{A}/\text{mM cm}^2$)	Linearity (mM)	Limit of detection (μM)	Ref.
2019	Pt/rGO/poly(3-aminobenzoic acid)	0.5	22	0.25–6	44.3	[84]
2019	Pt/Ni@rGO	0.5	171.92	0.02–5.0	6.3	[85]
2020	GO _x -Pt NPs-PAA (poly(Azure A))	0.2	42.7	0.02–2.3	7.6	[86]
2020	Nanoporous Pt	0.4	-	1–13	-	[87]
2020	Pd@Pt octahedral (76.2 nm)	-0.05	74.71 28.1 53.14	0.25–6 6–20 0.25–5	20.4	[88]
2020	Pd@Pt rhombic dodecahedral (79.3 nm)	-0.05	20.1	5–20	33.5	[88]
2020	Pd@Pt nanocubic (62.7 nm)	-0.05	44.3 22.9	0.25–5 5–20	24.1	[88]
2021	Pt/o-phenylenediamine- β -cyclodextrin/Au	0.25	22	2.5–15	750	[89]
2021	Pt/Au nanoalloy	0.55	2.82	1.39–13.9	482	[90]
2021	Polyurethane-poly(ethylene glycol)/Pt film/Au-polyethylene terephthalate)	0.65	3.418	0.5–25	0.25	[91]
2021	Pt nanodendrite/ZnO nanorods	-0.5	20.19	0–20	0.5	[92]
2022	Concave Pt-Pd/Au	-0.05	11.06	2.4–10.6	0.15	[93]
2022	Core-shell Pt-Pd/Au	-0.05	9.939	2.4–9.4	0.14	[93]
2022	Core-shell Pt-Pd-Pt Island/Au	-0.05	9.715	1.8–9.4	0.14	[93]
2022	Stellated Pt-Pd/Au	-0.05	11.62	1.8–6	0.17	[93]
2022	GO/MWCNT/Au@Pt	-0.013	330	5×10^{-5} –0.1 0.1–2.5	42	[94]
2022	Single-atom platinum(Pt ₁)/Ni(OH) ₂ /N-doped graphene	0.48	220.75	0.01–2.18	-	[95]
2023	Pt/MXene	0.1	3.43	0–8	29.15	[96]
2023	Single-atom platinum (Pt ₁)/Cu@CuO NWs	0.131	852.16	10^{-5} – 5.18×10^{-3}	3.6	[97]
2023	Laser-scribed Pt NPs	-	69.64	0.005–3	0.23	[98]
2023	Pt nanoflower-rGO	-0.28	335.5	0–3.5	53	[99]
2023	Pt ₂ Pd ₁ alloy nanocrystals	-0.05	3.3	0.001–0.4	0.245	[100]
2024	Pt ₁ /Cu ₂ O@copper foam	0.55	31550	0.002–0.56	1	[101]
2024	Co ₃ O ₄ /Pt single-atoms	0.6	-	0.001–0.8	0.84	[102]

Recent research has focused on developing platinum-based electrochemical sensors with enhanced sensitivity, selectivity, and stability for non-enzymatic glucose detection. These advancements often involve using novel materials and fabrication techniques to optimize sensor performance. Lin et al. [90] investigated the potential of electrochemically deposited Pt/Au nanoalloy electrodes for neutral non-enzymatic glucose biosensing. Their research demonstrated the effectiveness of this nanoalloy material in achieving high specificity for glucose detection, with a sensitivity of $2.82 \mu\text{A}/\text{mM cm}^2$, a detection limit of 0.482 mM , and a linear range of $1.39\text{--}13.9 \text{ mM}$. Furthermore, experiments performed in artificial serum demonstrated that this Pt/Au nanoalloy electrode could be effectively used for potential clinical purposes, emphasizing its durability against various complex interfering substances present in human blood. Özbek et al. [103] demonstrated a promising glucose biosensor utilizing a graphene/platinum nanoparticle/Nafion composite on a glassy carbon electrode. The biosensor, developed through a cross-linking method, displayed remarkable selectivity and sensitivity for glucose detection, achieving a detection limit of 10 nM . The biosensor's performance was further validated by examining its stability over 20 measurements, showing a retention of 94.5% activity. The research also highlighted the biosensor's capability to precisely detect glucose in a synthetic blood sample, indicating its potential for clinical applications.

Several studies have confirmed the possibility of single-atom catalysts (SACs) for enhancing the electrochemical sensing of glucose. Long et al. [95] explored the use of single-atom platinum (Pt) supported on $\text{Ni}(\text{OH})_2$ nanoplates/nitrogen-doped graphene ($\text{Pt}_1/\text{Ni}(\text{OH})_2/\text{NG}$) as a novel catalyst. This SAC exhibited a significantly improved performance compared to $\text{Ni}(\text{OH})_2$ alone, demonstrating a lower anode peak potential (0.48 V) and a 12-fold increase in sensitivity ($220.75 \mu\text{A}/\text{mM cm}^2$). The $\text{Pt}_1/\text{Ni}(\text{OH})_2/\text{N}$ -doped graphene catalyst also displayed remarkable selectivity against common interfering species, a rapid response time of 4.6 seconds , and exceptional stability over four weeks. This research highlights the promising potential of SACs to enhance electrochemical sensing applications significantly. Wang et al. [94] produced a novel non-enzymatic electrochemical glucose sensor utilizing a 3D composite material comprised of GO, MWCNTs, and Au@Pt core-shell nanoparticles. This sensor exhibited a remarkable detection limit of $4.2 \times 10^{-8} \text{ M}$ with two linear ranges: 1×10^{-4} to $2.5 \times 10^{-3} \text{ M}$ and 5×10^{-8} to $1 \times 10^{-4} \text{ M}$. This research highlighted the potential of this 3D composite material as a practical platform for non-enzymatic glucose detection.

The recent advancements in non-enzymatic electrochemical glucose sensors highlight significant innovations in materials and design to improve sensitivity, selectivity, and practicality for continuous monitoring. Li et al. [96] developed a flexible wearable sensor using a Pt/MXene catalyst, which showed a wide detection range for glucose in sweat ($0\text{--}8 \text{ mmol/l}$) and incorporated a conductive hydrogel for enhanced stability. This design included a microfluidic patch for efficient sweat collection, demonstrating its potential for real-time glucose monitoring, which is particularly beneficial for diabetes management. Zhao et al. [97] focused on single-atom platinum supported on Cu@CuO core-shell nanowires ($\text{Pt}_1/\text{Cu}@/\text{CuO}$ NWs). Their findings revealed exceptional electrocatalytic activity with a significantly reduced onset potential and an impressive sensitivity of $852.163 \mu\text{A}/\text{mM cm}^2$. The synergy between the single Pt atoms and the

core-shell structure contributed to vital glucose binding, showcasing the efficacy of single-atom catalysts (SACs) in glucose sensing.

Wang et al. [101] explored Pt SACs on cuprous oxide nanowires ($\text{Pt}_1/\text{Cu}_2\text{O}@/\text{copper foam}$) for glucose detection. Utilizing advanced characterization methods, they achieved an ultrahigh sensitivity of $31.55 \text{ mA}/\text{mM cm}^2$ and a low detection limit of $1 \mu\text{M}$. First-principles simulations indicated that the SACs enhanced glucose adsorption and facilitated electron transfer, reinforcing the potential of SACs in developing highly sensitive biosensors. Zhang et al. [102] introduced a sensor based on Pt SACs supported on Co_3O_4 , integrated with a dual-channel microfluidic chip and a PEG-DA hydrogel. This setup provided rapid and reliable glucose detection with a linear range of 1 to $800 \mu\text{M}$ and a detection limit of $0.84 \mu\text{M}$. The hydrogel minimized interference, while the microfluidic design improved reaction conditions, demonstrating high recovery rates in actual beverage samples.

These investigations underscore the transformative possibility of novel materials and designs to enhance the efficiency of electrochemical glucose sensors, paving the way for more effective diabetes management solutions.

5. Performance evaluation of platinum-based electrochemical glucose sensors

The performance of platinum-based electrochemical sensors for the detection of glucose has shown significant advancements over the years. This section evaluates various attributes such as potential, sensitivity, linearity, and limit of detection (LOD) across different modified electrodes, highlighting the challenges and progress in this field.

The potential at which these sensors operate varies widely, with most modified electrodes functioning in the range of -0.5 V to 0.65 V . Notably, electrodes such as the $\text{Pt}/\text{Ni}@/\text{rGO}$ and $\text{Pt}_1/\text{Cu}_2\text{O}@/\text{copper foam}$ demonstrated effective performance at 0.5 V and 0.55 V , respectively, showcasing their ability to detect glucose efficiently while minimizing interference from other species. In contrast, several sensors, such as the Pd@Pt octahedral and Pd@Pt rhombic dodecahedral, operate at negative potentials (-0.05 V), which may be beneficial for reducing background current but could also impact the overall sensitivity.

Sensitivity is a critical parameter for evaluating sensor performance. The data reveals a wide range of sensitivities, with the $\text{Pt}_1/\text{Cu}@/\text{CuO}$ NWs achieving an impressive sensitivity of $852.16 \mu\text{A}/\text{mM cm}^2$, making it one of the most sensitive sensors reported to date. Other notable sensors include $\text{Pt}_1/\text{Ni}(\text{OH})_2/\text{N}$ -doped graphene ($220.75 \mu\text{A}/\text{mM cm}^2$) and $\text{GO}/\text{MWCNT}/\text{Au}@/\text{Pt}$ ($330 \mu\text{A}/\text{mM cm}^2$). However, several sensors exhibited lower sensitivity values, such as Pt/Au nanoalloy ($2.82 \mu\text{A}/\text{mM cm}^2$) and Pt nanodendrite/ZnO nanorods ($20.19 \mu\text{A}/\text{mM cm}^2$), indicating that further optimization is necessary for these configurations.

The linearity of the response is crucial for practical applications, as it determines the concentration range over which the sensor can reliably function. Most sensors exhibit a linear response within specific concentration ranges, with notable examples including Pt/rGO/poly(3-aminobenzoic acid) ($0.25\text{--}6 \text{ mM}$) and $\text{Pt}_1/\text{Cu}_2\text{O}@/\text{copper foam}$ ($0.002\text{--}0.56 \text{ mM}$). The most comprehensive linear range is observed in polyurethane-poly(ethylene glycol)/Pt film/Au-polyethylene

terephthalate (0.5–25 mM), demonstrating its potential for applications requiring detection across a broad glucose concentration spectrum. However, some sensors, like nanoporous Pt and Pd@Pt octahedral, show limited linearity ranges, indicating a need for further development to enhance their applicability.

The LOD is another critical parameter that reflects the sensor's ability to detect low glucose concentrations. Several sensors have reported impressive LOD values, with Pt₁/Cu@CuO NWs achieving a remarkable LOD of 3.6 μ M and GO/MWCNT/Au@Pt showing a LOD of 42 μ M. Conversely, sensors like Pt/Au nanoalloy and Pt nanodendrite/ZnO nanorods have higher LODs (482 μ M and 750 μ M, respectively), suggesting that while they may be suitable for higher glucose concentrations, they are less effective for detecting low levels of glucose in clinical settings.

In conclusion, evaluating platinum-based electrochemical glucose sensors indicates significant progress in enhancing sensitivity, reducing LOD, and expanding linearity ranges. However, ongoing research is essential to address limitations in potential operation and sensitivity across various electrode modifications to optimize these sensors for practical applications in the monitoring of glucose.

6. Conclusions and outlook

This mini-review has provided a comprehensive overview of platinum-based electrochemical sensors for glucose detection, highlighting the advancements in material design, fabrication techniques, and single-atom catalysts. Platinum's exceptional electrocatalytic properties and inherent stability have made it a cornerstone material for developing susceptible, selective, and stable glucose sensors.

The performance evaluation of these sensors reveals significant progress in achieving remarkable sensitivity, more comprehensive linear ranges, and lower detection limits. Sensors incorporating platinum nanoparticles, composites, and single-atom catalysts have demonstrated impressive performance, achieving sensitivities exceeding 850 μ A/mM cm^2 and detection limits as low as 3.6 μ M. However, the development of platinum-based sensors continues to face challenges, including the requirement for enhanced stability, selectivity, and cost-effectiveness.

Future research in this field will focus on:

- Exploring novel platinum-based materials: Investigating platinum alloys, core-shell structures, and advanced nanomaterials to enhance catalytic activity, selectivity, and stability.
- Developing advanced fabrication techniques: Utilizing electrodeposition, electrospinning, and 3D printing for precise control of platinum-based nanomaterials' morphology, size, and distribution.
- Integrating microfluidic platforms: Developing miniaturized sensors with integrated microfluidics for enhanced performance, portability, and real-time monitoring capacities.
- Embracing the potential of single-atom catalysis: Unveiling the possibilities of single-atom platinum catalysts to further enhance sensitivity, selectivity, and response time, instilling a sense of hope and optimism in the audience.

Developing efficient, cost-effective, and reliable platinum-based electrochemical glucose sensors is crucial for improving diabetes management, advancing biomedical research, and enabling point-of-care diagnostics. The audience is encouraged to continue their research and development in this field, as it holds immense promise for

revolutionizing glucose detection technology and transforming healthcare practices.

CRedit authorship contribution statement

Milad Khanchoupan: Resources, Conceptualization, Writing – original draft.

Alireza Pishavar: Writing – original draft, Writing – review & editing.

Donya Souri: Resources, Writing – original draft

Reza Yusofvand: Writing – original draft, Writing – review & editing.

Zeynab Dabirifar: Supervision.

Data availability

The data underlying this article will be shared on reasonable request to the corresponding author.

Declaration of competing interest

The authors declare no competing interests.

Funding and acknowledgment

The authors declare that this study did not receive funding from any sources. Additionally, there are no acknowledgments to report.

References

- [1] L.C. Clark Jr, C. Lyons, Electrode systems for continuous monitoring in cardiovascular surgery, *Ann. N. Y. Acad. Sci.* 102 (1962) 29–45. <https://doi.org/10.1111/j.1749-6632.1962.tb13623.x>.
- [2] J.H. Halsey Jr, L.C. Clark Jr, Some regional circulatory abnormalities following experimental cerebral infarction, *Neurology*. 20 (1970) 238–238. <https://doi.org/10.1212/WNL.20.3.238>.
- [3] K. Dhara, J. Stanley, T. Ramachandran, B.G. Nair, T.G. Babu, Pt-CuO nanoparticles decorated reduced graphene oxide for the fabrication of highly sensitive non-enzymatic disposable glucose sensor, *Sens. Actuators B*. 195 (2014) 197–205. <https://doi.org/10.1016/j.snb.2014.01.044>.
- [4] M. Govindaraj, J. Rajendran, U.G. PK, M.K. Muthukumar, B. Jayaraman, Graphitic carbon nitride nanosheets decorated with strontium tungstate nanospheres as an electrochemical transducer for sulfamethazine sensing, *ACS Appl. Nano Mater.* 6 (2023) 930–945. <https://doi.org/10.1021/acsanm.2c04322>.
- [5] A. Pourali, M.R. Rashidi, J. Barar, G. Pavon-Djavid, Y. Omid, Voltammetric biosensors for analytical detection of cardiac troponin biomarkers in acute myocardial infarction, *TrAC, Trends Anal. Chem.* 134 (2021) 116123. <https://doi.org/10.1016/j.trac.2020.116123>.
- [6] K. Li, W. Liu, Y. Ni, D. Li, D. Lin, et al., Technical synthesis and biomedical applications of graphene quantum dots, *J. Mater. Chem. B*. 5 (2017) 4811–4826. <https://doi.org/10.1039/C7TB01073G>.
- [7] H. Chen, S. Zhou, J. Chen, J. Zhou, K. Fan, et al., An integrated plant glucose monitoring system based on microneedle-enabled electrochemical sensor, *Biosens. Bioelectron.* 248 (2024) 115964. <https://doi.org/10.1016/j.bios.2023.115964>.
- [8] A. Galant, R. Kaufman, J. Wilson, Glucose: Detection and analysis, *Food Chem.* 188 (2015) 149–160. <https://doi.org/10.1016/j.foodchem.2015.04.071>.
- [9] Q. Niu, C. Bao, X. Cao, C. Liu, H. Wang, W. Lu, Ni-Fe PBA hollow nanocubes as efficient electrode materials for highly sensitive detection of guanine and hydrogen peroxide in human whole saliva, *Biosens. Bioelectron.* 141 (2019) 111445. <https://doi.org/10.1016/j.bios.2019.111445>.

- [10] A. Sanati, Y. Esmaceli, E. Bidram, L. Shariati, M. Rafienia, et al., Recent advancement in electrode materials and fabrication, microfluidic designs, and self-powered systems for wearable non-invasive electrochemical glucose monitoring, *Appl. Mater. Today*. 26 (2022) 101350. <https://doi.org/10.1016/j.apmt.2021.101350>.
- [11] T. Saha, R. Del Caño, K. Mahato, E. De la Paz, C. Chen, et al., Wearable electrochemical glucose sensors in diabetes management: a comprehensive review, *Chem. Rev.* 123 (2023) 7854–7889. <https://doi.org/10.1021/acs.chemrev.3c00078>.
- [12] D. Papandreou, E. Magriplis, M. Abboud, Z. Taha, E. Karavolia, et al., Consumption of raw orange, 100% fresh orange juice, and nectar-sweetened orange juice—effects on blood glucose and insulin levels on healthy subjects, *Nutrients*. 11 (2019) 2171. <https://doi.org/10.3390/nu11092171>.
- [13] P. Mirmiran, S. Hosseinpour-Niazi, L. Moghaddam-Banaem, M. Lamyian, A. Goshtasebi, F. Azizi, Inverse relation between fruit and vegetable intake and the risk of gestational diabetes mellitus, *Int. J. Vitam. Nutr. Res.* 89 (2019) 37–44. <https://doi.org/10.1024/0300-9831/a000475>.
- [14] H. Teymourian, A. Barfidokht, J. Wang, Electrochemical glucose sensors in diabetes management: an updated review (2010–2020), *Chem. Soc. Rev.* 49 (2020) 7671–7709. <https://doi.org/10.1039/D0CS00304B>.
- [15] C.H. Chou, J.C. Chen, C.C. Tai, I.W. Sun, J.M. Zen, A Nonenzymatic Glucose Sensor Using Nanoporous Platinum Electrodes Prepared by Electrochemical Alloying/Dealloying in a Water-Insensitive Zinc Chloride-1-Ethyl-3-Methylimidazolium Chloride Ionic Liquid, *Electroanalysis*. 20 (2008) 771–775. <https://doi.org/10.1002/elan.200704102>.
- [16] A. Heller, B. Feldman, Electrochemical glucose sensors and their applications in diabetes management, *Chem. Rev.* 108 (2008) 2482–2505. <https://doi.org/10.1021/cf068069y>.
- [17] H. Lee, Y.J. Hong, S. Baik, T. Hyeon, D.H. Kim, Enzyme-based glucose sensor: from invasive to wearable device, *Adv. Healthcare Mater.* 7 (2018) 1701150. <https://doi.org/10.1002/adhm.201701150>.
- [18] J. Okuda-Shimazaki, H. Yoshida, K. Sode, FAD dependent glucose dehydrogenases—Discovery and engineering of representative glucose sensing enzymes, *Bioelectrochemistry*. 132 (2020) 107414. <https://doi.org/10.1016/j.bioelechem.2019.107414>.
- [19] G. Emir, Y. Dilgin, S. Şahin, C. Akgul, A self-powered enzymatic glucose sensor utilizing bimetallic nanoparticle composites modified pencil graphite electrodes as cathode, *Appl. Biochem. Biotechnol.* (2024) 1–16. <https://doi.org/10.1007/s12010-024-05068-1>.
- [20] S.S. Nematı, G. Dehghan, S. Rashtbari, T.N. Tan, A. Khataee, Enzyme-based and enzyme-free metal-based glucose biosensors: Classification and recent advances, *Microchem. J.* 193 (2023) 109038. <https://doi.org/10.1016/j.microc.2023.109038>.
- [21] Q.-Q. Yang, S.-B. He, Y.-L. Zhang, M. Li, X.-H. You, et al., A colorimetric sensing strategy based on chitosan-stabilized platinum nanoparticles for quick detection of α -glucosidase activity and inhibitor screening, *Anal. Bioanal. Chem.* (2024) 1–10. <https://doi.org/10.1007/s00216-024-05198-9>.
- [22] H. Yu, J. Yu, L. Li, Y. Zhang, S. Xin, et al., Recent progress of the practical applications of the platinum nanoparticle-based electrochemistry biosensors, *Front. Chem.* 9 (2021) 677876. <https://doi.org/10.3389/fchem.2021.677876>.
- [23] B. Wu, H. Xu, Y. Shi, Z. Yao, J. Yu, et al., Microelectrode glucose biosensor based on nanoporous platinum/graphene oxide nanostructure for rapid glucose detection of tomato and cucumber fruits, *Food Qual. Saf.* 6 (2022) fyab030. <https://doi.org/10.1093/fqsafe/fyab030>.
- [24] M.H. Hassan, C. Vyas, B. Grieve, P. Bartolo, Recent Advances in Enzymatic and Non-Enzymatic Electrochemical Glucose Sensing, *Sensors*. 21 (2021) 4672. <https://doi.org/10.3390/s21144672>.
- [25] J.D. Newman, A.P.F. Turner, Home blood glucose biosensors: a commercial perspective, *Biosens. Bioelectron.* 20 (2005) 2435–2453. <https://doi.org/10.1016/j.bios.2004.11.012>.
- [26] P. D'Orazio, Biosensors in clinical chemistry, *Clin. Chim. Acta*. 334 (2003) 41–69. [https://doi.org/10.1016/S0009-8981\(03\)00241-9](https://doi.org/10.1016/S0009-8981(03)00241-9).
- [27] V.B. Juska, M.E. Pemble, A Critical Review of Electrochemical Glucose Sensing: Evolution of Biosensor Platforms Based on Advanced Nanosystems, *Sensors*. 20 (2020) 6013. <https://doi.org/10.3390/s20216013>.
- [28] E.-H. Yoo, S.-Y. Lee, Glucose Biosensors: An Overview of Use in Clinical Practice, *Sensors*. 10 (2010) 4558–4576. <https://doi.org/10.3390/s100504558>.
- [29] D. Matthews, E. Bown, A. Watson, R. Holman, J. Steemson, et al., Pen-sized digital 30-second blood glucose meter, *Lancet*. 329 (1987) 778–779. [https://doi.org/10.1016/s0140-6736\(87\)92802-9](https://doi.org/10.1016/s0140-6736(87)92802-9).
- [30] H.H. Ipekci, O. Kazak, A. Tor, A. Uzunoglu, Tuning active sites of N-doped porous carbon catalysts derived from vinasse for high-performance electrochemical sensing, *Part. Sci. Technol.* 41 (2023) 93–104. <https://doi.org/10.1080/02726351.2022.2056724>.
- [31] A.F. Quintero-Jaime, F. Conzuelo, W. Schuhmann, D. Cazorla-Amorós, E. Morallón, Multi-wall carbon nanotubes electrochemically modified with phosphorus and nitrogen functionalities as a basis for bioelectrodes with improved performance, *Electrochim. Acta*. 387 (2021) 138530. <https://doi.org/10.1016/j.electacta.2021.138530>.
- [32] A.F. Quintero-Jaime, F. Conzuelo, D. Cazorla-Amorós, E. Morallón, Pyrroloquinoline quinone-dependent glucose dehydrogenase bioelectrodes based on one-step electrochemical entrapment over single-wall carbon nanotubes, *Talanta*. 232 (2021) 122386. <https://doi.org/10.1016/j.talanta.2021.122386>.
- [33] B. Xue, K. Li, L. Feng, J. Lu, L. Zhang, Graphene wrapped porous Co₃O₄/NiCo₂O₄ double-shelled nanocages with enhanced electrocatalytic performance for glucose sensor, *Electrochim. Acta*. 239 (2017) 36–44. <https://doi.org/10.1016/j.electacta.2017.04.005>.
- [34] D. Jiang, Z. Chu, J. Peng, J. Luo, Y. Mao, et al., One-step synthesis of three-dimensional Co(OH)₂/rGO nano-flowers as enzyme-mimic sensors for glucose detection, *Electrochim. Acta*. 270 (2018) 147–155. <https://doi.org/10.1016/j.electacta.2018.03.066>.
- [35] D. Thatikayala, D. Ponnamma, K.K. Sadasivuni, J.-J. Cabibihan, A.K. Al-Ali, et al., Progress of Advanced Nanomaterials in the Non-Enzymatic Electrochemical Sensing of Glucose and H₂O₂, *Biosensors*. 10 (2020) 151. <https://doi.org/10.3390/bios10110151>.
- [36] M. Wei, Y. Qiao, H. Zhao, J. Liang, T. Li, et al., Electrochemical non-enzymatic glucose sensors: recent progress and perspectives, *Chem. Commun.* 56 (2020) 14553–14569. <https://doi.org/10.1039/D0CC05650B>.
- [37] C.W. Lee, J.M. Suh, H.W. Jang, Chemical sensors based on two-dimensional (2D) materials for selective detection of ions and molecules in liquid, *Front. Chem.* 7 (2019) 708. <https://doi.org/10.3389/fchem.2019.00708>.
- [38] V. Georgakilas, M. Otyepka, A.B. Bourlino, V. Chandra, N. Kim, et al., Functionalization of Graphene: Covalent and Non-Covalent Approaches, Derivatives and Applications, *Chem. Rev.* 112 (2012) 6156–6214. <https://doi.org/10.1021/cr3000412>.
- [39] P.G. Moses, J.J. Mortensen, B.I. Lundqvist, J.K. Nørskov, Density functional study of the adsorption and van der Waals binding of aromatic and conjugated compounds on the basal plane of MoS₂, *J. Chem. Phys.* 130 (2009) 104709. <https://doi.org/10.1063/1.3086040>.
- [40] C. Berger, Z. Song, X. Li, X. Wu, N. Brown, et al., Electronic confinement and coherence in patterned epitaxial graphene, *Science*. 312 (2006) 1191–1196. <https://doi.org/10.1126/science.1125925>.
- [41] Y. Wang, Y. Shao, D.W. Matson, J. Li, Y. Lin, Nitrogen-Doped Graphene and Its Application in Electrochemical Biosensing, *ACS Nano*. 4 (2010) 1790–1798. <https://doi.org/10.1021/nn100315s>.
- [42] J. Luo, S. Jiang, H. Zhang, J. Jiang, X. Liu, A novel non-enzymatic glucose sensor based on Cu nanoparticle modified graphene sheets electrode, *Anal. Chim. Acta*. 709 (2012) 47–53. <https://doi.org/10.1016/j.aca.2011.10.025>.
- [43] Y.H. Kwak, D.S. Choi, Y.N. Kim, H. Kim, D.H. Yoon, et al., Flexible glucose sensor using CVD-grown graphene-based field

- effect transistor, *Biosens. Bioelectron.* 37 (2012) 82–87. <https://doi.org/10.1016/j.bios.2012.04.042>.
- [44] O. Parlak, A. İncel, L. Uzun, A.P.F. Turner, A. Tiwari, Structuring Au nanoparticles on two-dimensional MoS₂ nanosheets for electrochemical glucose biosensors, *Biosens. Bioelectron.* 89 (2017) 545–550. <https://doi.org/10.1016/j.bios.2016.03.024>.
- [45] S. Su, C. Zhang, L. Yuwen, X. Liu, L. Wang, et al., Uniform Au@Pt core–shell nanodendrites supported on molybdenum disulfide nanosheets for the methanol oxidation reaction, *Nanoscale.* 8 (2016) 602–608. <https://doi.org/10.1039/C5NR06077J>.
- [46] J. Huang, Y. He, J. Jin, Y. Li, Z. Dong, R. Li, A novel glucose sensor based on MoS₂ nanosheet functionalized with Ni nanoparticles, *Electrochim. Acta.* 136 (2014) 41–46. <https://doi.org/10.1016/j.electacta.2014.05.070>.
- [47] X. Lin, Y. Ni, S. Kokot, Electrochemical and bio-sensing platform based on a novel 3D Cu nano-flowers/layered MoS₂ composite, *Biosens. Bioelectron.* 79 (2016) 685–692. <https://doi.org/10.1016/j.bios.2015.12.072>.
- [48] X. Zhong, H. Yang, S. Guo, S. Li, G. Gou, et al., In situ growth of Ni–Fe alloy on graphene-like MoS₂ for catalysis of hydrazine oxidation, *J. Mater. Chem. A.* 22 (2012) 13925–13927. <https://doi.org/10.1039/C2JM32427J>.
- [49] Z. Sun, Q. Zhao, G. Zhang, Y. Li, G. Zhang, et al., Exfoliated MoS₂ supported Au–Pd bimetallic nanoparticles with core–shell structures and superior peroxidase-like activities, *RSC Adv.* 5 (2015) 10352–10357. <https://doi.org/10.1039/C4RA13575J>.
- [50] J. Li, Z. Yang, Y. Tang, Y. Zhang, X. Hu, Carbon nanotubes–nanoflake-like SnS₂ nanocomposite for direct electrochemistry of glucose oxidase and glucose sensing, *Biosens. Bioelectron.* 41 (2013) 698–703. <https://doi.org/10.1016/j.bios.2012.09.059>.
- [51] S. Narla, M. Jones, K. Hermayer, Y. Zhu, Critical care glucose point-of-care testing, *Advances in Clinical Chemistry*, Elsevier. (2016) 97–121. <https://doi.org/10.1016/bs.acc.2016.05.002>.
- [52] S. Ferri, K. Kojima, K. Sode, Review of glucose oxidases and glucose dehydrogenases: a bird's eye view of glucose sensing enzymes, *J. Diabetes Sci. Technol.* 5 (2011) 1068–1076. <https://doi.org/10.1177/193229681100500507>.
- [53] A. Harper, M.R. Anderson, Electrochemical glucose sensors—developments using electrostatic assembly and carbon nanotubes for biosensor construction, *Sensors.* 10 (2010) 8248–8274. <https://doi.org/10.3390/s100908248>.
- [54] R. Wilson, A. Turner, Glucose oxidase: an ideal enzyme, *Biosens. Bioelectron.* 7 (1992) 165–185. [https://doi.org/10.1016/0956-5663\(92\)87013-F](https://doi.org/10.1016/0956-5663(92)87013-F).
- [55] J. Raba, H.A. Mottola, Glucose oxidase as an analytical reagent, *Crit. Rev. Anal. Chem.* 25 (1995) 1–42. <https://doi.org/10.1080/10408349508050556>.
- [56] J. John, S.J. Crennell, D.W. Hough, M.J. Danson, G.L. Taylor, The crystal structure of glucose dehydrogenase from *Thermoplasma acidophilum*, *Structure.* 2 (1994) 385–393. [https://doi.org/10.1016/s0969-2126\(00\)00040-x](https://doi.org/10.1016/s0969-2126(00)00040-x).
- [57] S. Bagheri, N.M. Julkapli, Modified iron oxide nanomaterials: functionalization and application, *J. Magn. Magn. Mater.* 416 (2016) 117–133. <https://doi.org/10.1016/j.jmmm.2016.05.042>.
- [58] V. Guzsvány, J. Anojčić, E. Radulović, O. Vajdle, I. Stanković, et al., Screen-printed enzymatic glucose biosensor based on a composite made from multiwalled carbon nanotubes and palladium containing particles, *Microchim. Acta.* 184 (2017) 1987–1996. <https://doi.org/10.1007/s00604-017-2188-1>.
- [59] C. He, M. Xie, F. Hong, X. Chai, H. Mi, et al., A highly sensitive glucose biosensor based on gold nanoparticles/bovine serum albumin/Fe₃O₄ biocomposite nanoparticles, *Electrochim. Acta.* 222 (2016) 1709–1715. <https://doi.org/10.1016/j.electacta.2016.11.162>.
- [60] P. Rafeighi, M. Tavahodi, B. Haghighi, Fabrication of a third-generation glucose biosensor using graphene-polyethyleneimine-gold nanoparticles hybrid, *Sens. Actuators B.* 232 (2016) 454–461. <https://doi.org/10.1016/j.snb.2016.03.147>.
- [61] P.K. Robinson, *Enzymes: principles and biotechnological applications*, *Essays Biochem.* 59 (2015) 1. <https://doi.org/10.1042/bse0590001>.
- [62] N. Mohamad Nor, N.S. Ridhuan, K. Abdul Razak, Progress of Enzymatic and Non-Enzymatic Electrochemical Glucose Biosensor Based on Nanomaterial-Modified Electrode, *Biosensors.* 12 (2022) 1136. <https://doi.org/10.3390/bios12121136>.
- [63] S.A. Pullano, M. Greco, M.G. Bianco, D. Foti, A. Brunetti, A.S. Fiorillo, Glucose biosensors in clinical practice: Principles, limits and perspectives of currently used devices, *Theranostics.* 12 (2022) 493. <https://doi.org/10.7150/thno.64035>.
- [64] C. Sabu, T. Henna, V. Raphey, K. Nivitha, K. Pramod, Advanced biosensors for glucose and insulin, *Biosens. Bioelectron.* 141 (2019) 111201. <https://doi.org/10.1016/j.bios.2019.03.034>.
- [65] J. Wang, N.V. Myung, M. Yun, H.G. Monbouquette, Glucose oxidase entrapped in polypyrrole on high-surface-area Pt electrodes: a model platform for sensitive electroenzymatic biosensors, *J. Electroanal. Chem.* 575 (2005) 139–146. <https://doi.org/10.1016/j.jelechem.2004.08.023>.
- [66] H. Zhu, Y. Zhu, X. Yang, C. Li, Multiwalled carbon nanotubes incorporated with dendrimer encapsulated with Pt nanoparticles: an attractive material for sensitive biosensors, *Chem. Lett.* 35 (2006) 326–327. <https://doi.org/10.1246/cl.2006.326>.
- [67] A. Guiseppi-Elie, C. Lei, R.H. Baughman, Direct electron transfer of glucose oxidase on carbon nanotubes, *Nanotechnology.* 13 (2002) 559. <https://doi.org/10.1088/0957-4484/13/5/303>.
- [68] B.-Y. Wu, S.-H. Hou, F. Yin, Z.-X. Zhao, Y.-Y. Wang, et al., Amperometric glucose biosensor based on multilayer films via layer-by-layer self-assembly of multi-wall carbon nanotubes, gold nanoparticles and glucose oxidase on the Pt electrode, *Biosens. Bioelectron.* 22 (2007) 2854–2860. <https://doi.org/10.1016/j.bios.2006.11.028>.
- [69] Z. Wen, S. Ci, J. Li, Pt nanoparticles inserting in carbon nanotube arrays: nanocomposites for glucose biosensors, *J. Phys. Chem. C.* 113 (2009) 13482–13487. <https://doi.org/10.1021/jp902830z>.
- [70] M. Yang, F. Qu, Y. Lu, Y. He, G. Shen, R. Yu, Platinum nanowire nanoelectrode array for the fabrication of biosensors, *Biomaterials.* 27 (2006) 5944–5950. <https://doi.org/10.1016/j.biomaterials.2006.08.014>.
- [71] C. Feng, G. Xu, H. Liu, J. Lv, Z. Zheng, Y. Wu, Facile fabrication of Pt/graphene/TiO₂ NTAs based enzyme sensor for glucose detection, *J. Electrochem. Soc.* 161 (2013) B1. <https://doi.org/10.1149/2.025401jes>.
- [72] B. Akkaya, B. Çakiroğlu, M. Özacar, Tannic Acid-Reduced Graphene Oxide Deposited with Pt Nanoparticles for Switchable Bioelectronics and Biosensors Based on Direct Electrochemistry, *ACS Sustainable Chem. Eng.* 6 (2018) 3805–3814. <https://doi.org/10.1021/acssuschemeng.7b04164>.
- [73] H. Yang, Q. Shi, Y. Song, X. Li, C. Zhu, et al., Glucose biosensor based on mesoporous Pt nanotubes, *J. Electrochem. Soc.* 164 (2017) B230. <https://doi.org/10.1149/2.1421706jes>.
- [74] M. Zhao, Z. Li, Z. Han, K. Wang, Y. Zhou, et al., Synthesis of mesoporous multiwall ZnO nanotubes by replicating silk and application for enzymatic biosensor, *Biosens. Bioelectron.* 49 (2013) 318–322. <https://doi.org/10.1016/j.bios.2013.05.017>.
- [75] C. Zhu, D. Du, A. Eychemüller, Y. Lin, Engineering Ordered and Nonordered Porous Noble Metal Nanostructures: Synthesis, Assembly, and Their Applications in Electrochemistry, *Chem. Rev.* 115 (2015) 8896–8943. <https://doi.org/10.1021/acs.chemrev.5b00255>.
- [76] I. Strauss, A. Mundstock, M. Treger, K. Lange, S. Hwang, et al., Metal–Organic Framework Co-MOF-74-Based Host–Guest Composites for Resistive Gas Sensing, *ACS Appl. Mater. Interfaces.* 11 (2019) 14175–14181. <https://doi.org/10.1021/acsami.8b22002>.
- [77] M.B. Majewski, A.J. Howarth, P. Li, M.R. Wasielewski, J.T. Hupp, O.K. Farha, Enzyme encapsulation in metal–organic frameworks for

- applications in catalysis, *CrystEngComm*. 19 (2017) 4082–4091. <https://doi.org/10.1039/C7CE00022G>.
- [78] Y. Hu, L. Dai, D. Liu, W. Du, Y. Wang, Progress & prospect of metal-organic frameworks (MOFs) for enzyme immobilization (enzyme/MOFs), *Renewable Sustainable Energy Rev.* 91 (2018) 793–801. <https://doi.org/10.1016/j.rser.2018.04.103>.
- [79] X.-C. Xie, K.-J. Huang, X. Wu, Metal-organic framework derived hollow materials for electrochemical energy storage, *J. Mater. Chem. A*. 6 (2018) 6754–6771. <https://doi.org/10.1039/C8TA00612A>.
- [80] G. Luo, H. Xie, Y. Niu, J. Liu, Y. Huang, et al., Electrochemical myoglobin biosensor based on magnesium metal-organic frameworks and gold nanoparticles composite modified electrode, *Int. J. Electrochem. Sci.* 14 (2019) 2405–2413. <https://doi.org/10.20964/2019.03.41>.
- [81] D. Uzak, A. Atiroğlu, V. Atiroğlu, B. Çakıroğlu, M. Özacar, Reduced graphene oxide/Pt nanoparticles/Zn-MOF-74 nanomaterial for a glucose biosensor construction, *Electroanalysis*. 32 (2020) 510–519. <https://doi.org/10.1002/elan.201900599>.
- [82] A. Şavk, H. Aydın, K. Cellat, F. Şen, A novel high performance non-enzymatic electrochemical glucose biosensor based on activated carbon-supported Pt-Ni nanocomposite, *J. Mol. Liq.* 300 (2020) 112355. <https://doi.org/10.1016/j.molliq.2019.112355>.
- [83] Y. Liu, Y. Ding, Y. Zhang, Y. Lei, Pt-Au nanocorals, Pt nanofibers and Au microparticles prepared by electrospinning and calcination for nonenzymatic glucose sensing in neutral and alkaline environment, *Sens. Actuators B*. 171 (2012) 954–961. <https://doi.org/10.1016/j.snb.2012.06.009>.
- [84] S. Phetsang, J. Jakmunee, P. Mungkornasawakul, R. Laocharoensuk, K. Ounnunkad, Sensitive amperometric biosensors for detection of glucose and cholesterol using a platinum/reduced graphene oxide/poly(3-aminobenzoic acid) film-modified screen-printed carbon electrode, *Bioelectrochemistry*. 127 (2019) 125–135. <https://doi.org/10.1016/j.bioelechem.2019.01.008>.
- [85] R. Ayranci, B. Demirkan, B. Sen, A. Şavk, M. Ak, F. Şen, Use of the monodisperse Pt/Ni@rGO nanocomposite synthesized by ultrasonic hydroxide assisted reduction method in electrochemical nonenzymatic glucose detection, *Mater. Sci. Eng. C*. 99 (2019) 951–956. <https://doi.org/10.1016/j.msec.2019.02.040>.
- [86] F. Jiménez-Fiérrez, M.I. González-Sánchez, R. Jiménez-Pérez, J. Iniesta, E. Valero, Glucose Biosensor Based on Disposable Activated Carbon Electrodes Modified with Platinum Nanoparticles Electrodeposited on Poly(Azure A), *Sensors*. 20 (2020) 4489. <https://doi.org/10.3390/s20164489>.
- [87] W. McCormick, D. McCrudden, Development of a highly nanoporous platinum screen-printed electrode and its application in glucose sensing, *J. Electroanal. Chem.* 860 (2020) 113912. <https://doi.org/10.1016/j.jelechem.2020.113912>.
- [88] T.-P. Wang, B.-D. Hong, Y.-M. Lin, C.-L. Lee, Catalysis of the D-glucose Oxidation Reaction Using Octahedral, Rhombic Dodecahedral, and Cubic Pd@Pt Core-Shell Nanoparticles, *Appl. Catal. B*. 260 (2020) 118140. <https://doi.org/10.1016/j.apcatb.2019.118140>.
- [89] J. Madden, C. Barrett, F.R. Laffir, M. Thompson, P. Galvin, A. O' Riordan, On-Chip Glucose Detection Based on Glucose Oxidase Immobilized on a Platinum-Modified, Gold Microband Electrode, *Biosensors*. 11 (2021) 249. <https://doi.org/10.3390/bios11080249>.
- [90] F.-Y. Lin, P.-Y. Lee, T.-F. Chu, C.-I. Peng, G.-J. Wang, Neutral Nonenzymatic Glucose Biosensors Based on Electrochemically Deposited Pt/Au Nanoalloy Electrodes, *Int. J. Nanomed.* 16 (2021) 5551–5563. <https://doi.org/10.2147/IJN.S321480>.
- [91] R. Feng, Y. Chu, X. Wang, Q. Wu, F. Tang, A long-term stable and flexible glucose sensor coated with poly(ethylene glycol)-modified polyurethane, *J. Electroanal. Chem.* 895 (2021) 115518. <https://doi.org/10.1016/j.jelechem.2021.115518>.
- [92] N.S. Ridhuan, N. Mohamad Nor, K. Abdul Razak, Z. Lockman, N.D. Zakaria, ITO electrode modified with Pt nanodendrites-decorated ZnO nanorods for enzymatic glucose sensor, *J. Solid State Electrochem.* 25 (2021) 1065–1072. <https://doi.org/10.1007/s10008-020-04884-9>.
- [93] S.-S. Wang, W.-J. Qiu, T.-P. Wang, C.-L. Lee, Tuning structures of Pt shells on Pd nanocubes as neutral glucose oxidation catalysts and sensors, *Appl. Surf. Sci.* 605 (2022) 154670. <https://doi.org/10.1016/j.apsusc.2022.154670>.
- [94] R. Wang, X. Liu, Y. Zhao, J. Qin, H. Xu, et al., Novel electrochemical non-enzymatic glucose sensor based on 3D Au@Pt core-shell nanoparticles decorated graphene oxide/multi-walled carbon nanotubes composite, *Microchem. J.* 174 (2022) 107061. <https://doi.org/10.1016/j.microc.2021.107061>.
- [95] B. Long, Y. Zhao, P. Cao, W. Wei, Y. Mo, et al., Single-Atom Pt Boosting Electrochemical Nonenzymatic Glucose Sensing on Ni(OH)₂/N-Doped Graphene, *Anal. Chem.* 94 (2022) 1919–1924. <https://doi.org/10.1021/acs.analchem.1c04912>.
- [96] Q.-F. Li, X. Chen, H. Wang, M. Liu, H.-L. Peng, Pt/MXene-Based Flexible Wearable Non-Enzymatic Electrochemical Sensor for Continuous Glucose Detection in Sweat, *ACS Appl. Mater. Interfaces*. 15 (2023) 13290–13298. <https://doi.org/10.1021/acsami.2c20543>.
- [97] Y. Zhao, Y. Jiang, Y. Mo, Y. Zhai, J. Liu, et al., Boosting electrochemical catalysis and nonenzymatic sensing toward glucose by Single-Atom Pt supported on Cu@CuO Core-Shell nanowires, *Small*. 19 (2023) 2207240. <https://doi.org/10.1002/sml.202207240>.
- [98] Y. Wang, H. Guo, M. Yuan, J. Yu, Z. Wang, X. Chen, One-step laser synthesis platinum nanostructured 3D porous graphene: A flexible dual-functional electrochemical biosensor for glucose and pH detection in human perspiration, *Talanta*. 257 (2023) 124362. <https://doi.org/10.1016/j.talanta.2023.124362>.
- [99] S. Gengan, R.M. Gnanamuthu, S. Sankaranarayanan, V.M. Reddy, B.C. Marepally, R.K. Biroju, Electrochemical modified Pt nanoflower @ rGO for non-enzymatic electrochemical sensing of glucose, *Sens. Actuators A*. 353 (2023) 114232. <https://doi.org/10.1016/j.sna.2023.114232>.
- [100] W. Han, X. Zhang, R. Wang, T. Bai, H. Liu, et al., Non-enzymatic electrochemical glucose sensor based on Pt₂Pd₁ alloy nanocrystals with high-index facets, *J. Alloys Compd.* 936 (2023) 168287. <https://doi.org/10.1016/j.jallcom.2022.168287>.
- [101] Z. Wang, J. Wu, W. Wei, M. Gao, Y.-W. Zhang, et al., Pt single-atom electrocatalysts at Cu₂O nanowires for boosting electrochemical sensing toward glucose, *Chem. Eng. J.* 495 (2024) 153564. <https://doi.org/10.1016/j.cej.2024.153564>.
- [102] Y. Zhang, X. Zeng, Y. Liu, C. Wang, C. Jin, et al., Pt Single-Atom Catalyst on Co₃O₄ for the Electrocatalytic Detection of Glucose, *ACS Appl. Nano Mater.* 7 (2024) 13693–13700. <https://doi.org/10.1021/acsanm.4c02227>.
- [103] M.A. Özbek, A. Yaşar, S. Çete, E. Er, N. Erk, A novel biosensor based on graphene/platinum nanoparticles/Nafion composites for determination of glucose, *J. Solid State Electrochem.* 25 (2021) 1601–1610. <https://doi.org/10.1007/s10008-021-04939-5>.